

NINJA®

**Intelli-Sense
Kitchen System**

CT682ANZ

INSTRUCTIONS



ninjakitchen.com.au
ninjakitchen.co.nz





AUS 1800 099 385
NZ 0800 112 660



 **TIP:** You can find the model and serial numbers on the QR code label located near the rating label.

REGISTER YOUR PURCHASE

-  registeryourninja.com.au/register
-  AUS 1800 099 385 or NZ 0800 112 660
-  Scan QR code using mobile device

RECORD THIS INFORMATION

Model Number: _____
Serial Number: _____
Date of Purchase (Keep receipt): _____
Store of Purchase: _____

TECHNICAL SPECIFICATIONS

Voltage: 220-240V~, 50-60Hz
Watts: 1200W

PLEASE READ CAREFULLY AND KEEP FOR FUTURE REFERENCE.

These instructions are designed to help you get a complete understanding of your new Ninja Intelli-Sense Kitchen System.

If you have any questions, please call our Customer Service line at AUS 1800 099 385 or NZ 0800 112 660.

Important Safety Instructions..... 3

Getting to Know Your Ninja® Intelli-Sense Kitchen System..... 7

Before First Use 9

Features..... 10

Total Crushing Pitcher10

Single-Serve Cup..... 11

Precision Processor Bowl12

Using Your Total Crushing Pitcher 13

Using Your Single-Serve Cup..... 17

Using Your Precision Processor Bowl 21

Assembling Your Auto-Spiralizer 25

Using Your Auto-Spiralizer 27

Care & Maintenance..... 31

Cleaning31

Storing.....31

Resetting the Motor Thermostat.....31

Ordering Replacement Parts31

Troubleshooting Guide..... 32

Warranty 34



This appliance complies with the WEEE-Directive 2012/19/EU on the disposal of electrical and electronic equipment (WEEE).



This marking indicates this product should not be disposed of with other household wastes throughout the EU. To prevent possible harm to the environment or human health from uncontrolled waste disposal, recycle it responsibly to promote the sustainable reuse of material sources. To return your used device, please use the return and collection systems or contact the retailer where this product was purchased. They can take this product for environmentally safe recycling.

This appliance complied with the European directives for electromagnetic compatibility (EMC) 2014/30/EU and its revisions, as well as Low Voltage Directive (LVD) 2014/35/EU and its revisions.



IMPORTANT SAFETY INSTRUCTIONS

PLEASE READ CAREFULLY BEFORE USE • FOR HOUSEHOLD USE ONLY

⚠ WARNING

To reduce the risk of injury, fire, electrical shock or property damage, basic safety precautions must always be followed, including the following numbered warnings and subsequent instructions. This appliance shall not be used by children. Keep the appliance and its cord out of reach of children. Children shall not play with the appliance.

- 1 Read all instructions prior to using the appliance and its accessories.
- 2 Carefully observe and practice all warnings and instructions. This unit contains electrical connections and moving parts that potentially present risk to the user.
- 3 This product is provided with a Stacked Blade Assembly. **ALWAYS** exercise care when handling the Stacked Blade Assembly. The Stacked Blade Assembly is sharp and is **NOT** locked to the container. It is designed to be removable to facilitate cleaning and replacement if needed. **ALWAYS** grasp the Stacked Blade Assembly by the top of the shaft. Failure to use care when handling the Stacked Blade Assembly will result in a risk of laceration.
- 4 Take your time and exercise care during unpacking and appliance setup. This appliance contains sharp, loose blades that can cause injury if mishandled.
- 5 Take inventory of all contents to ensure you have all parts needed to properly and safely operate your appliance.
- 6 Unplug the appliance from the outlet when not in use, before assembling or disassembling parts, and before cleaning. To unplug, grasp the plug by the body and pull from the outlet. **NEVER** unplug by grasping and pulling the flexible cord.
- 7 Wash all parts that may contact food before use. Follow washing instructions covered in this instruction manual.
- 8 To protect against the risk of electric shock, **DO NOT** submerge the appliance or allow the power cord to contact any form of liquid.
- 9 **DO NOT** use this appliance outdoors. It is designed for indoor household use only.
- 10 **DO NOT** operate any appliance with a damaged cord or plug, or after the appliance malfunctions or is dropped or damaged in any manner. This appliance has no user-serviceable parts. If damaged, contact SharkNinja for servicing.
- 11 This appliance has important markings on the plug blade. The entire supply cord is not suitable for replacement. If damaged, please contact SharkNinja for service.
- 12 Extension cords should not be used with this appliance.
- 13 **DO NOT** allow young children to operate this appliance or use as a toy. Close supervision is necessary when any appliance is used near children.
- 14 This appliance is not intended to be used by people (including children) with reduced physical, sensory, or mental capabilities, or lack of experience and knowledge, unless they have been given supervision or instruction concerning use of the appliance by a person responsible for their safety.
- 15 Before each use, inspect blade assemblies for damage. If a blade is bent or damage is suspected, contact SharkNinja to arrange for replacement.
- 16 **DO NOT** attempt to sharpen blades.
- 17 **DO NOT** allow the cord to hang over the edges of tables or counters. The cord may become snagged and pull the appliance off the work surface.
- 18 **DO NOT** allow the unit or the cord to contact hot surfaces, including stoves and other heating appliances.
- 19 **ALWAYS** use the appliance on a clean, dry, level surface.
- 20 **NEVER** place a blade assembly on the motor base without it first being attached to its corresponding container and lid.
- 21 Keep hands, hair, and clothing out of the container when loading and operating.
- 22 **ONLY** use attachments and accessories that are provided with the product or are recommended by SharkNinja. The use of attachments not recommended or sold by SharkNinja may cause fire, electric shock, or injury.
- 23 During operation and handling of the appliance, avoid contact with moving parts.

CONTINUED ON PAGE 5

SAVE THESE INSTRUCTIONS

IMPORTANT SAFETY INSTRUCTIONS

PLEASE READ CAREFULLY BEFORE USE • FOR HOUSEHOLD USE ONLY

⚠ WARNING

To reduce the risk of injury, fire, electrical shock or property damage, basic safety precautions must always be followed, including the following numbered warnings and subsequent instructions. This appliance shall not be used by children. Keep the appliance and its cord out of reach of children. Children shall not play with this appliance.

- 24 DO NOT** operate the appliance with an empty container.
- 25 DO NOT** fill containers past the max fill or max liquid lines.
- 26 DO NOT** microwave any containers or accessories provided with the appliance.
- 27** Before operation, ensure all utensils are removed from containers. Failure to remove utensils can cause containers to shatter and potentially result in personal injury and property damage.
- 28** Keep hands and utensils out of container while blending to reduce the risk of severe injury to persons or damage to the blender. A scraper or spatula may be used but must be used **ONLY** when the appliance is not running.
- 29 NEVER** operate the appliance without lids and caps in place. **DO NOT** attempt to defeat the interlock mechanism. Ensure the container and lid are properly installed before operation.
- 30 DO NOT** expose the containers and accessories to extreme temperature changes. They may experience damage.
- 31 NEVER** leave the appliance unattended while in use.
- 32 DO NOT** open pour spout cover while blender is operating.
- 33 DO NOT** blend hot liquids. Doing so may result in a pressure buildup and steam exposure that can pose a risk of the user being burned.
- 34** If you find unmixed ingredients sticking to the sides of the pitcher, stop the appliance, remove the lid, and use a scraper or spatula to dislodge ingredients. **NEVER** insert your hands into the pitcher, as you may contact one of the blades and experience a laceration.
- 35 DO NOT** attempt to remove the container and lid from the motor base while the motor and Stacked Blade Assembly are still spinning. Allow the appliance to come to a complete stop before removing the lid and pitcher.
- 36** Upon completion of blending, ensure the Stacked Blade Assembly is removed **BEFORE** emptying pitcher contents. The Stacked Blade Assembly is to be removed by grasping the top of the shaft and lifting from the pitcher. Failure to remove the Stacked Blade Assembly before emptying the pitcher can result in a risk of laceration.
- 37** If the appliance overheats, a thermal switch will activate and temporarily disable the motor. To reset, unplug the appliance and allow it to cool for approximately 15 minutes before using again.
- 38** The maximum wattage rating for this appliance is based on the configuration of the Stacked Blade Assembly and Total Crushing Pitcher. Other configurations may draw less power or current.
- 39 DO NOT** spray the motor base or touchscreen with water or other liquids.
- 40** Turn off the appliance and unplug the motor base before cleaning.

SAVE THESE INSTRUCTIONS

GETTING TO KNOW YOUR NINJA® INTELLI-SENSE KITCHEN SYSTEM

WELCOME!

Congratulations on your purchase. Use this instruction manual to learn about the great features of your Ninja Intelli-Sense Kitchen System. From assembly to use to maintenance, you will find it all in here.

There are a variety of accessories that are compatible with this blender series.

NOTE: The top flap of your box shows the select accessories that are included with your model.

To find great recipes and purchase more accessories (including more Blade Discs for creating different types of noodles) please visit ninjaaccessories.com

If you have any questions, concerns or feedback, we'd love to hear from you. Give us a call at AUS 1800 099 385 or NZ 0800 112 660 or visit ninjakitchen.com.au

*64 oz. max liquid capacity.

**3.5 cups max capacity/
15 oz. max liquid capacity.

MAIN UNIT

- A** Pitcher Lid
- B** 72 oz. Total Crushing Pitcher*
- C** Stacked Blade Assembly
- D** Motor Base with Smart Vessel Recognition
- E** 24 oz. Single-Serve Cup
- F** Spout Lid
- G** Pro Extractor Blades Assembly
- H** Precision Processor Bowl Lid
- I** Dough Blade Assembly
- J** Chopping Blade Assembly
- K** Precision Processor Bowl**
- L** Spiralizer Food Pusher
- M** Feed Chute Lid
- N** Collecting Bowl
- O** Spiralizer Bowl
- P** Spaghetti Blade Disc
- Q** Fettuccine Blade Disc
- R** Cleaning Brush

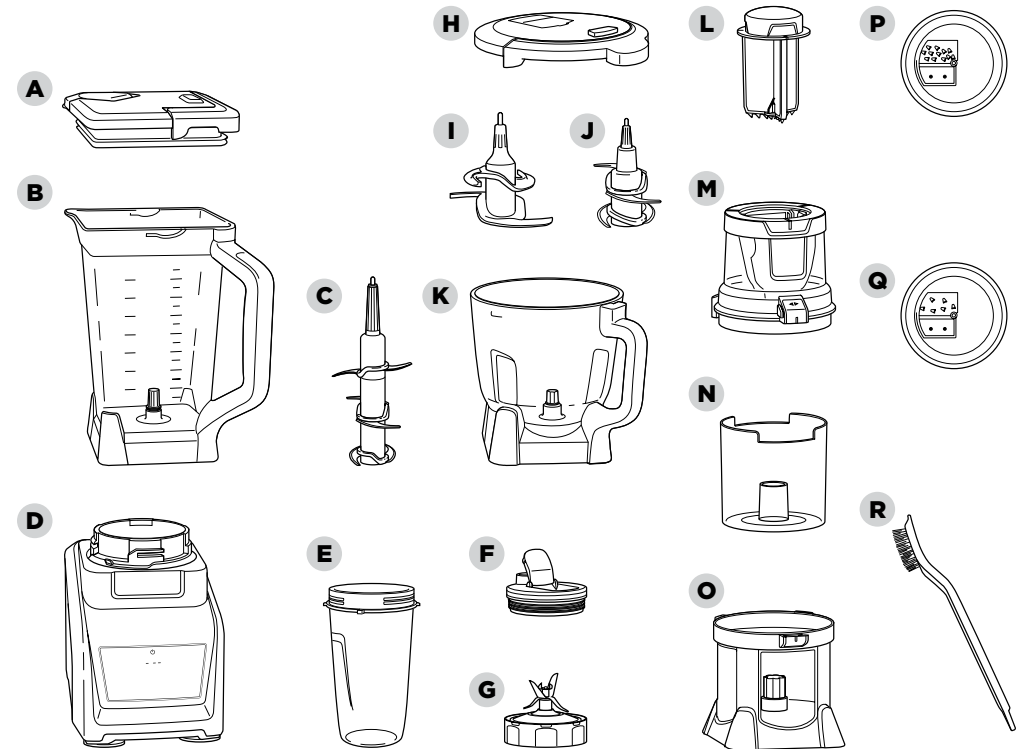

BEFORE FIRST USE

★ **IMPORTANT:** Review all warnings on pages 3–6 before proceeding.

DID YOU KNOW?

- You can take your drinks on the go using the Spout Lid.
- All containers, blade assemblies, blade discs, and lids are BPA free.
- Our containers, blade assemblies, and lids are all dishwasher safe.

- 1 Remove all packaging materials from the appliance. Exercise care when unpacking blade assemblies and Blade Discs. All blade assemblies and Blade Discs are sharp.
- 2 The Chopping Blade Assembly and Stacked Blade Assembly are **NOT** locked in place in their containers. Handle the Chopping Blade Assembly and Stacked Blade Assembly by grasping the top of the shaft.
- 3 Handle the Pro Extractor Blades Assembly by grasping around the perimeter of the blade assembly base.
- 4 Wash containers, lids, Blade Discs, and blade assemblies in warm, soapy, water using a dishwashing utensil with a handle or the provided cleaning brush to avoid direct contact with the blades. Exercise care when handling blade assemblies, as the blades are sharp.
- 5 Thoroughly rinse and air-dry all parts.
- 6 All attachments are dishwasher safe. It is recommended that the lids, Blade Discs, and blade assemblies be placed on the top rack of the dishwasher. Ensure blade assemblies and Blade Discs are removed from their containers before placing in the dishwasher. Exercise care when handling blade assemblies or Blade Discs.
- 7 Wipe touchscreen with a soft cloth. Allow it to dry completely before using.

FEATURES

SMART PROGRAMS FOR THE TOTAL CRUSHING PITCHER

Intelligent pre-set programs combine unique blending and pausing patterns that do the work for you. Once a pre-set program is selected, it will start immediately. Press STOP to end it.

⏻ The power symbol should be used to turn your appliance on or off.

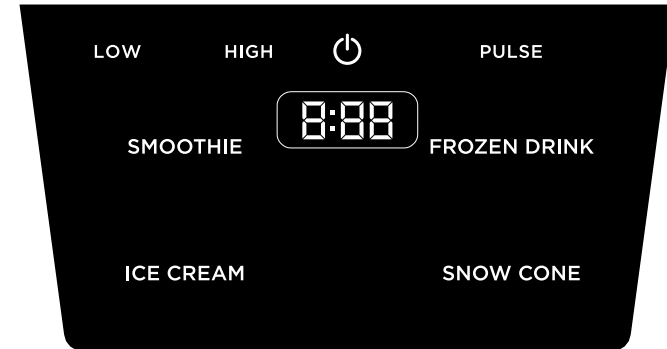

SMOOTHIE

Make super-smooth, sippable drinks and shakes from fresh or frozen fruit, liquids, and ice.

ICE CREAM

Create delicious and scoop-able frozen desserts like ice cream or sorbet.

FROZEN DRINK

Turn ice, juices, and fruit into expertly blended frozen drinks.

SNOW CONE

Pulverize ice into frozen creations like snow cones, slushies, or granitas.

LOW, HIGH, and PULSE

When selected, each of these programs runs continuously until turned off. They do not work in conjunction with any pre-set programs.

FEATURES - CONT.

SMART PROGRAMS FOR THE SINGLE-SERVE CUP

Intelligent pre-set programs combine unique blending and pausing patterns that do the work for you. Once a pre-set program is selected, it will start immediately. Press STOP to end it.

⏻ The power symbol should be used to turn your appliance on or off.

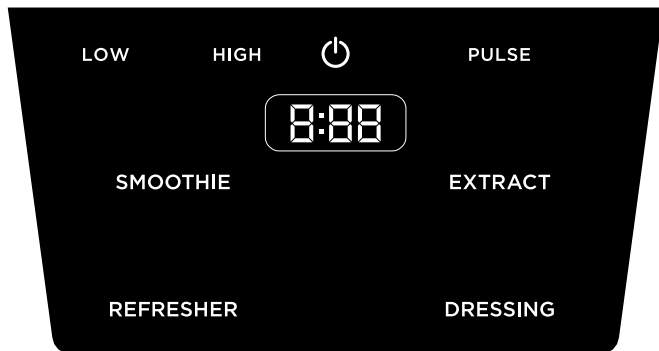

SMOOTHIE

Make super-smooth, sippable drinks and shakes from fresh or frozen fruit, liquids, and ice.

REFRESHER

Add natural veggie, fruit, and herb flavors to your water.

EXTRACT

Ideal for tough, leafy, or fibrous whole fruits and vegetables, including their skins, seeds, and stems.

DRESSING

Create fresh marinades, dressings, and sauces.

LOW, HIGH, and PULSE

When selected, each of these programs runs continuously until turned off. They do not work in conjunction with any pre-set programs.

SMART PROGRAMS FOR THE PRECISION PROCESSOR BOWL

Intelligent pre-set programs combine unique blending and pausing patterns that do the work for you. Once a pre-set program is selected, it will start immediately. Press STOP to end it.

⏻ The power symbol should be used to turn your appliance on or off.

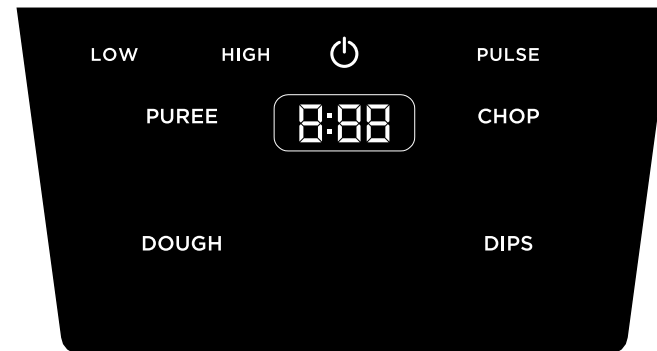

PUREE

Create anything from silky smooth sauces to the perfect hummus.

DOUGH

Ideal for creating delicious dough for pizza, bread, and baked goods like cookies.

CHOP

Timed pulses and pauses to give you consistent chopping results.

DIPS

Use for dips and sides with more texture like spinach and artichoke dip or mashed potatoes.

LOW, HIGH, and PULSE

When selected, each of these programs runs continuously until turned off. They do not work in conjunction with any pre-set programs.

USING YOUR TOTAL CRUSHING PITCHER

★ **IMPORTANT:** Review all warnings on pages 3–6 before proceeding.

💡 **TIP:** If the Stacked Blade Assembly is not fully seated, you will not be able to install and lock the lid into position.

💡 **TIP:** To learn more about the unit's programs, refer to page 10.

NOTE: Pre-set programs have pauses and changes in speed throughout the cycle.

NOTE: DO NOT add ingredients before completing installation of the Stacked Blade Assembly.

NOTE: The pitcher can only be installed in one orientation. The handle must be positioned on the front-right corner of the motor base to operate the appliance.

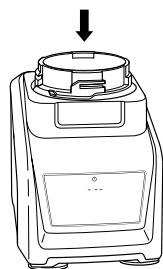

1 Place the unplugged motor base on a clean, dry, and level surface such as a countertop or table. Press downward on the motor base to adhere the suction cups to the work surface. Ensure the motor base is connected to power.

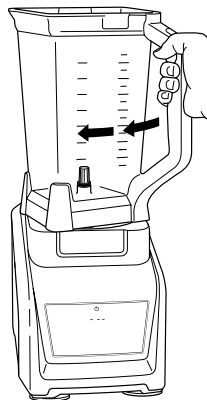

2 Lower the Total Crushing Pitcher onto the motor base. The handle should be aligned slightly to the right and the pitcher should be oriented so the LOCK symbols are visible on the motor base. Then rotate the pitcher clockwise until it clicks into place.

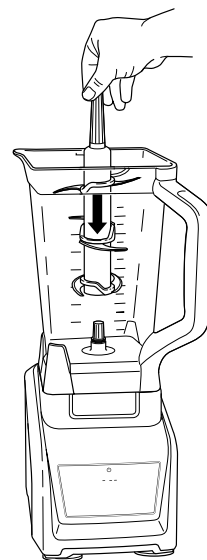

3 Exercising care, grasp the Stacked Blade Assembly by the top of the shaft and place it onto the drive gear inside the pitcher. Note that the blade assembly will fit loosely onto the drive gear.

4 Add ingredients, making sure to not exceed the Max Fill line marked on the side of the pitcher.

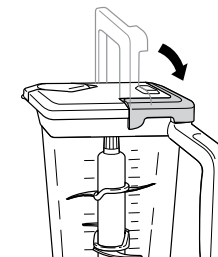

5 Place the lid on the pitcher, aligning the triangle symbol located on the lid with the triangle symbol located on the pitcher's handle. Press down on the handle until it clicks into place. The triangle symbols **MUST** be aligned for the lid to lock onto place and the unit to operate. When the unit is connected to power and the container is correctly locked into the motor base, press the Power symbol to turn unit on. The available program buttons will illuminate and the unit will be ready for use.

USING YOUR TOTAL CRUSHING PITCHER - CONT.

★ **IMPORTANT:** Review all warnings on pages 3–6 before proceeding.

★ **IMPORTANT:** As a safety feature, if the pitcher and lid are not properly installed, the timer will display “- --” and the motor will be disabled. If this happens, repeat step 5 on page 14. When the pitcher and lid are properly installed, the program buttons will illuminate steadily, indicating the appliance is ready for use.

NOTE: Smart Vessel Recognition can detect which container is on the motor base. Only the functions available for that particular container will illuminate on the touchscreen.

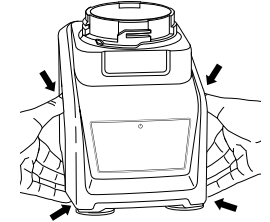
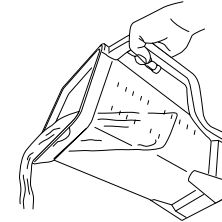
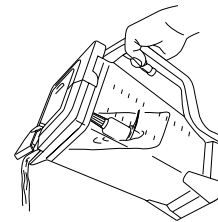
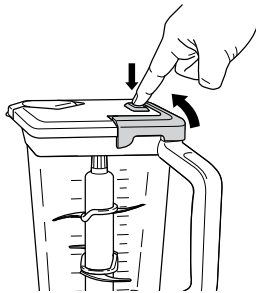
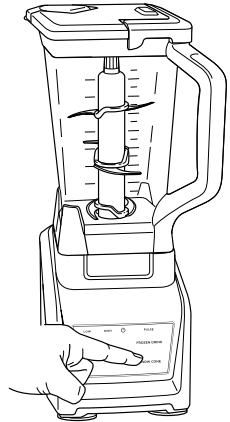

6 If using a pre-set program, first select the program that best suits your recipe. The pre-set feature will automatically stop the unit at the end of the program. To pause the appliance at any time, press the currently active button a second time. Reference page 10 for program descriptions.

7 If not using a pre-set program and ingredients have reached your desired consistency, stop the appliance by releasing the manual speed button, and wait for the appliance to come to a complete stop.

8 To remove the pitcher from the motor base, turn the pitcher counterclockwise and lift it up.

9 To pour out thinner mixtures, ensure the lid is locked in place, then open the pour spout cap.

10 For thicker mixtures that cannot be emptied through the pour spout, remove the lid and Stacked Blade Assembly before pouring. To remove the lid, press the RELEASE button and lift the handle. To remove the blade assembly, carefully grasp it by the top of the shaft. The pitcher can then be emptied.

11 Unplug the unit when finished. To release the motor base, place your hands underneath both sides of the motor base and gently pull the unit up and toward you. Refer to page 31 for storing instructions.

USING YOUR SINGLE-SERVE CUP

★ **IMPORTANT:** Review all warnings on pages 3–6 before proceeding.

NOTE: Pre-set programs have pauses and changes in speed throughout the cycle.

💡 **TIP:** To learn more about the unit's programs, refer to page 11.

NOTE: Pre-set programs have pauses and changes in speed throughout the cycle.

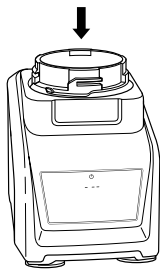

1 Place the unplugged motor base on a clean, dry, and level surface such as a countertop or table. Press downward on the motor base to adhere the suction cups to the work surface. Plug the motor base into a wall outlet.



2 Add ingredients to the Single-Serve Cup. **DO NOT** add ingredients past the MAX LIQUID line on the cup.

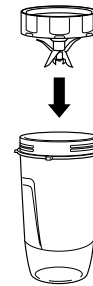

3 Install the Pro Extractor Blades Assembly onto the top of the cup. Twist the lid clockwise until it's sealed tightly.

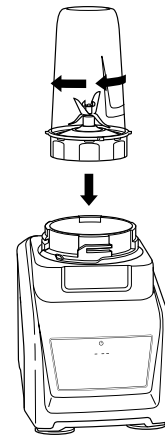

4 Turn the Single-Serve Cup upside down and install onto the motor base. Align the tabs on the cup with the slots on the base, then twist until it clicks into place. When the unit is connected to power and the container is correctly locked onto the motor base, press the Power symbol to turn unit on. The available program buttons will illuminate and the unit will be ready for use.

USING YOUR SINGLE-SERVE CUP - CONT.

★ **IMPORTANT:** Review all warnings on pages 3–6 before proceeding.

NOTE: Smart Vessel Recognition can detect which container is on the motor base. Only the functions available for that particular container will illuminate on the touchscreen.

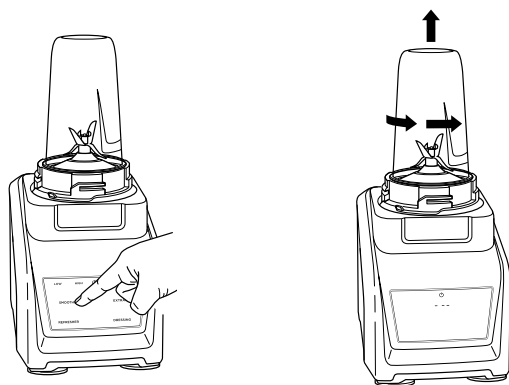

- 5 If using a pre-set program, first select the program that best suits your recipe. The pre-set feature will automatically stop the unit at the end of the program. To pause the appliance at any time, press the currently active program a second time. Reference page 11 for program descriptions.
- 6 To remove the cup from the motor base, turn the cup counterclockwise and then lift it.



- 7 Remove the Pro Extractor Blades Assembly by twisting the cap counterclockwise. Do not store blended contents with Pro Extractor Blades Assembly attached. Exercise care when handling the blade assembly, as the blades are sharp.

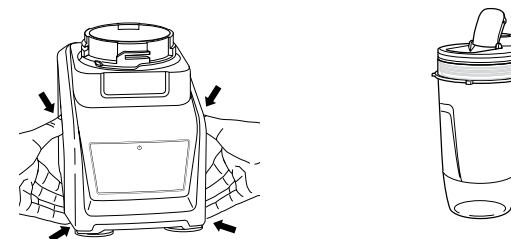

- 8 Unplug the unit when finished. To release the motor base, place your hands underneath both sides of the motor base and gently pull the unit up and toward you. Refer to page 31 for storing instructions.
- 9 To enjoy your drink on the go, place the Spout Lid onto the Single-Serve Cup and twist lid clockwise until firmly sealed. For storing ingredients in the cup, use only the Spout Lid to cover.

USING YOUR PRECISION PROCESSOR BOWL

★ **IMPORTANT:** Review all warnings on pages 3–6 before proceeding.

💡 **TIP:** If the blade assembly is not fully seated, you will not be able to install and lock the lid into position.

💡 **TIP:** To learn more about the unit's programs, refer to page 12.

NOTE: Pre-set programs have pauses and changes in speed throughout the cycle.

NOTE: DO NOT add ingredients before installing the blade assembly.

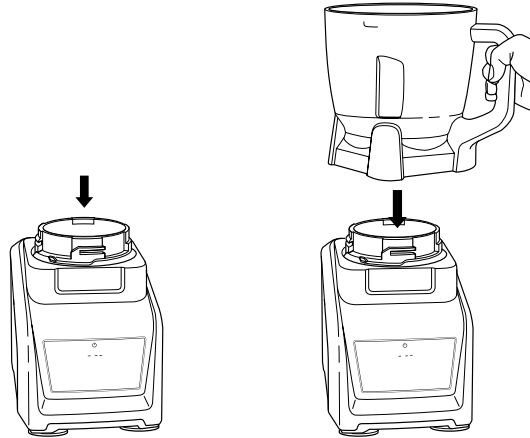

- 1** Place the unplugged motor base on a clean, dry, and level surface such as a countertop or table. Press downward on the motor base to adhere the suction cups to the work surface. Plug the motor base into a wall outlet.
- 2** Lower the Precision Processor bowl onto the motor base.

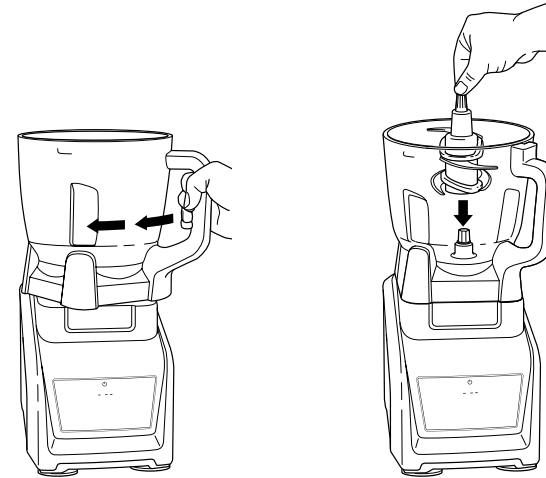

- 3** Rotate Precision Processor bowl clockwise until it clicks into place.
- 4** Exercising care, grasp the Chopping Blade Assembly by the top of the shaft and place it onto the drive gear inside the bowl. Note that the Chopping Blade Assembly will fit loosely onto the drive gear.
- 5** Add ingredients to the bowl, making sure not to exceed the MAX LIQUID and MAX FILL lines.

USING YOUR PRECISION PROCESSOR BOWL - CONT.

★ **IMPORTANT:** Review all warnings on pages 3–6 before proceeding.

NOTE: Please follow the same instructions to install the Dough Blade Assembly.

NOTE: Smart Vessel Recognition can detect which container is on the motor base. Only the functions available for that particular container will illuminate on the touchscreen.

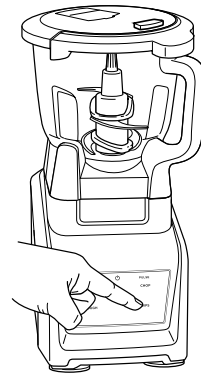
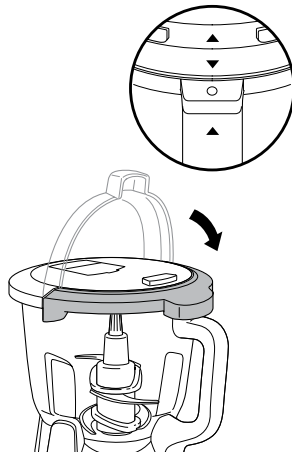

6 Place lid on Precision Processor Bowl, with black line on tab aligned slightly to the right of tab on front of bowl. Turn lid clockwise to lock in place. When properly locked, the white line on lid will line up with the black line on bowl. When the unit is connected to power and the container is correctly locked onto the motor base, press and hold Power symbol to turn unit on. The available program buttons will illuminate and the unit will be ready for use.

7 If using a pre-set program, first select the program that best suits your recipe. The pre-set feature will automatically stop the appliance at the end of the program. To pause the unit at any time, press the currently active program a second time. Reference page 12 for program descriptions.

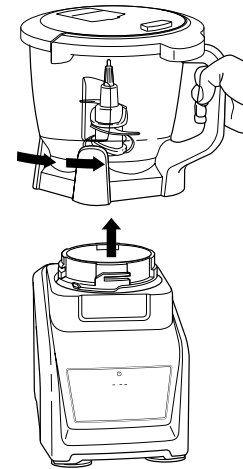

8 To remove the bowl from the motor base, turn the bowl counterclockwise and then lift it.

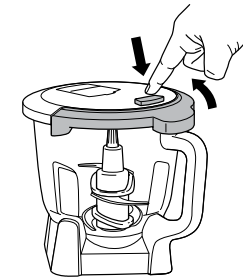

9 Remove the lid by pressing the release button on the front tab, twisting the lid counterclockwise, and lifting up. Always remove the Chopping Blade Assembly before emptying any of the ingredients in the bowl. To remove the Chopping Blade Assembly, carefully grasp it by the top of the shaft and lift it out of the bowl.

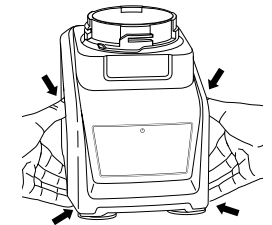

10 Unplug the unit when finished. To release the motor base, place your hands underneath both sides of the motor base and gently pull the unit up and toward you. Refer to page 31 for storing instructions.

ASSEMBLING YOUR AUTO-SPIRALIZER

★ **IMPORTANT:** Review all warnings on pages 3–6 before proceeding.

★ **IMPORTANT:** As a safety feature, if the Spiralizer Bowl and Feed Chute Lid are not properly installed, the timer will display “- -” and the motor will be disabled.

NOTE: To fit properly, the tabs on the sides of the Blade Disc must align with the gaps on the top of the Collecting Bowl.

NOTE: The Spiralizer accessory is only intended for processing of fruit and vegetables. Processing hard ingredients such as cheese, meats, and dried foods is not recommended.

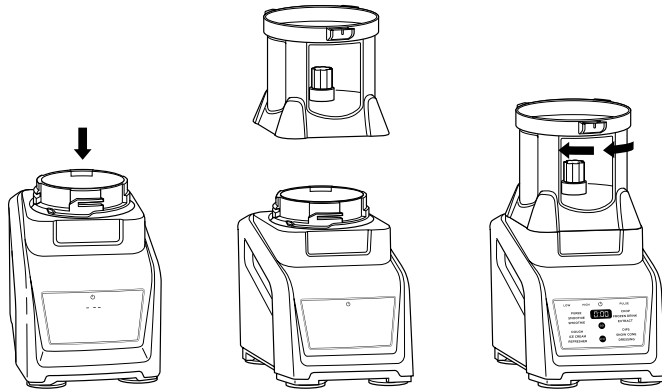

- 1 Place the unplugged motor base on a clean, dry, and level surface such as a countertop or table. Press downward on the motor base to adhere the suction cups to the work surface. Plug the motor base into a wall outlet.
- 2 Lower the Spiralizer Bowl onto the motor base.
- 3 Rotate the Spiralizer Bowl clockwise until it clicks into place.

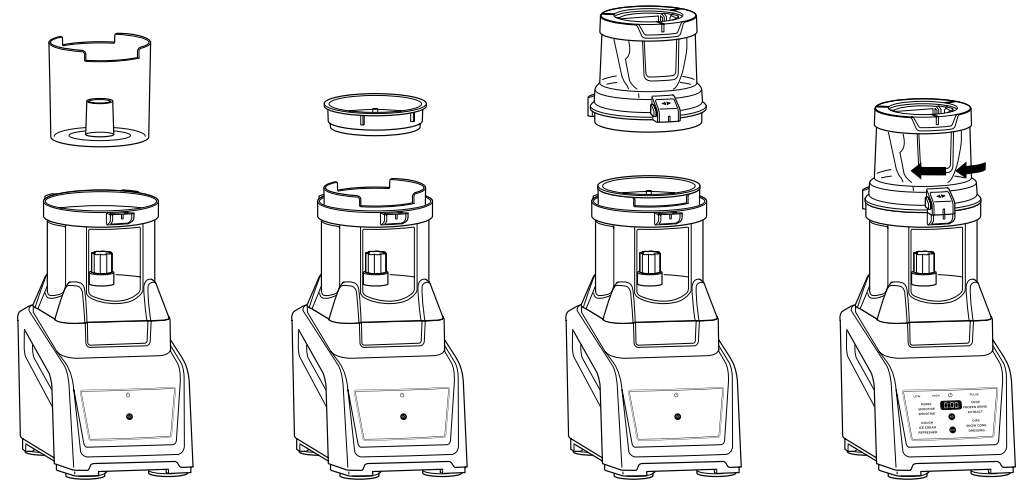

- 4 Place the Collecting Bowl inside the Spiralizer Bowl, aligning it over the gear post.
- 5 Choose your Blade Disc, making sure to handle it carefully.
- 6 Install the Blade Disc onto the top of the Collecting Bowl. The rim of the Blade Disc should sit flush against the top of the bowl, and the tabs on the sides of the Blade Discs must align with the slots on the top of the Collecting Bowl.
- 7 Assemble the Feed Chute Lid on top of the Spiralizer Bowl. Turn the lid clockwise onto the Spiralizer Bowl, aligning the gray tabs on the lid with the front of the bowl. When the unit is connected to power and the container is correctly assembled onto the motor base, press the Power symbol to turn unit on. The GO button will illuminate, indicating the unit is ready for use.

USING YOUR AUTO-SPIRALIZER

★ **IMPORTANT:** Review all warnings on pages 3–6 before proceeding.

★ **IMPORTANT:** After spiralizing an ingredient, all leftover pieces must be removed from the Collecting Bowl and Blade Disc before spiralizing again.

NOTE: To find out how to properly prep your ingredient, refer to the Food Prep section in your Quick Start Guide or your Inspiration Guide.

NOTE: Never spiralize multiple ingredients at one time.

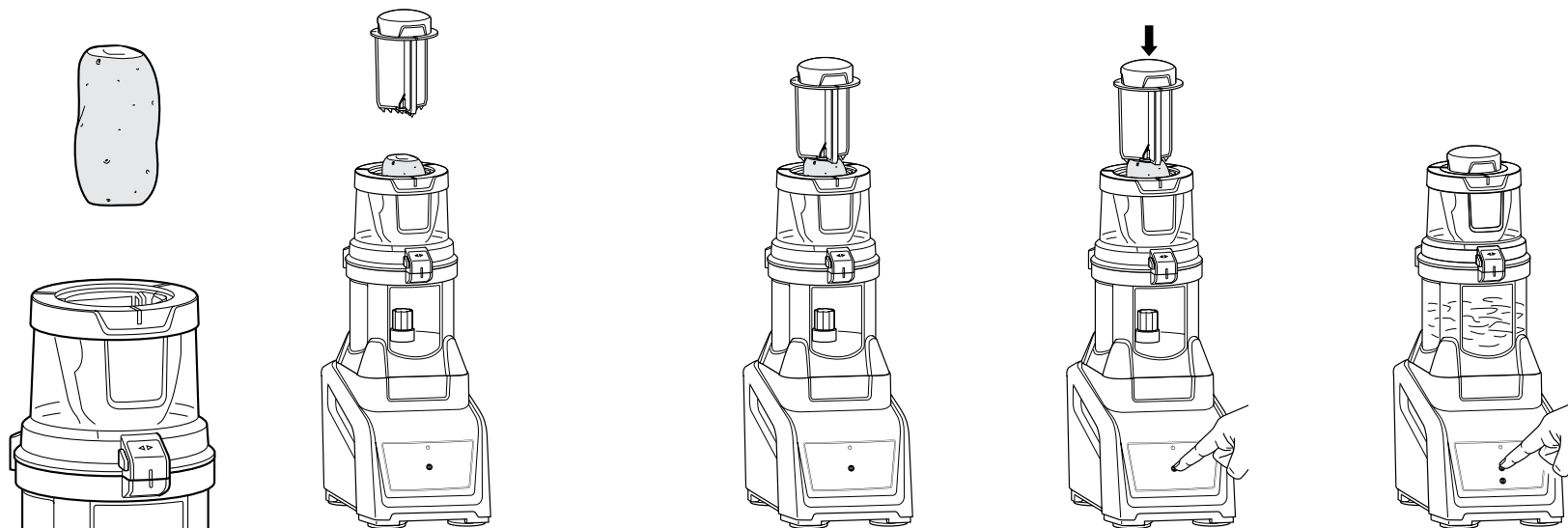

1 Before spiralizing, prepare your ingredient by cutting it so it is no more than 3 inches wide. Place the prepped ingredient into the Feed Chute, through the opening at the top.

2 Center the ingredient on the pin in the center of the Blade Disc, then push down, securing the ingredient onto the pin.

3 Place the Food Pusher on top of the ingredient and press down firmly to hold in place.

4 Select GO to begin spiralizing. Continue to press firmly with Food Pusher to guide ingredient through Feed Chute.

5 Spiralizing is complete when the Food Pusher sits flat atop the Feed Chute Lid. Press STOP to power off the motor.

USING YOUR AUTO-SPIRALIZER - CONT.

★ **IMPORTANT:** Review all warnings on pages 3–6 before proceeding.

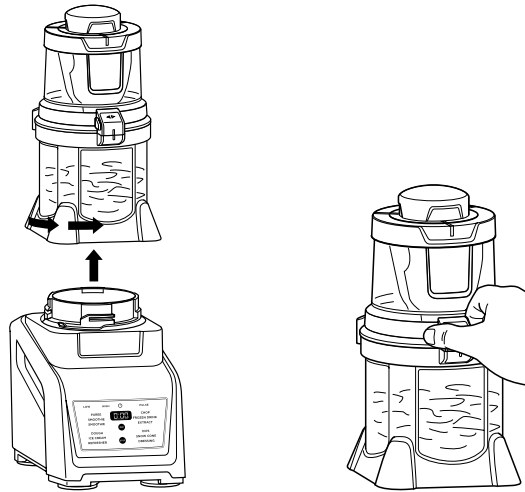

6 To remove the Spiralizer Bowl from the motor base, turn the bowl counterclockwise and lift.



7 To remove the Feed Chute Lid, press the release button on the left side of the front tab, then twist the lid counterclockwise and lift.

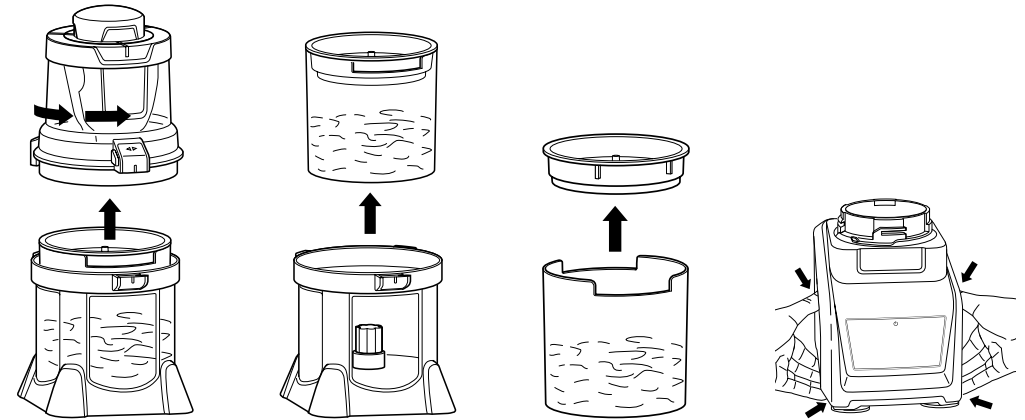

8 Remove the Collecting Bowl by lifting it out of the Spiralizer Bowl. Remove the Blade Disc by gripping the handles on the side of the disc and lifting.

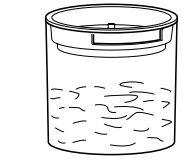

9 Remove the noodles from the Collecting Bowl and prepare as desired.

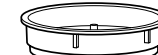

10 Unplug the appliance when finished. To release the motor base, place your hands underneath it and gently pull it toward you. Refer to page 31 for storing instructions.

CLEANING

- 1 Separate all parts.
- 2 Wash all containers in warm, soapy water with a soft cloth.

3 Hand-Washing

Wash blade assemblies and Blade Discs in warm, soapy water using a dishwashing utensil with a handle or the provided cleaning brush to avoid direct contact with the blades. Exercise care when handling when handling blade assemblies and Blade Discs as the blades are sharp. Thoroughly rinse and air-dry all parts.

Dishwasher

All attachments are dishwasher safe. It is recommended that the lids, containers, Blade Discs, and blade assemblies be placed on the top rack of the dishwasher **ONLY**. Ensure the when handling blade assemblies and Blade Discs are removed from their containers before placing in the dishwasher. Exercise care when handling when handling blade assemblies and Blade Discs.

Motor Base

Turn off the unit and unplug the motor base before cleaning. Wipe motor base with a clean, damp cloth.

Clean the touchscreen with a soft cloth, such as microfiber, to prevent scratching. To remove residue from the touchscreen, you may use an all-purpose cleaner.

NEVER spray the base or touchscreen with water or other liquids.

DO NOT use abrasive cloths/pads/brushes to clean the base or touchscreen, as this can dull or scratch the surface.

STORING

Wrap the power cord around the cord wrap on the back of the motor base. Store the unit upright and store all blade assemblies inside or attached to their respective containers with their lids locked into place.

DO NOT store blended or unblended ingredients in the Single-Serve Cup with the Pro Extractor Blades Assembly attached.

DO NOT stack items on top of the containers. Store any remaining attachments alongside the unit or in a cabinet where they will not be damaged or create a hazard.

RESETTING THE MOTOR THERMOSTAT

This unit features a unique safety system that prevents damage to the motor and drive system should you inadvertently overload it. If the unit is overloaded, the motor will be temporarily disabled. Should this occur, follow the reset procedure below.

- 1 Unplug the unit from the electrical outlet.
- 2 Allow the unit to cool for approximately 15 minutes.
- 3 Remove the container's lid and blade assembly. Empty the container and ensure no ingredients are jamming the blade assemblies.
- 4 Reset the unit in accordance with the applicable instructions for the container and blade type.

IMPORTANT: Ensure that maximum capacities are not exceeded. This is the most typical cause of appliance overload.

If your unit needs servicing, please call Customer Service at 1-877-646-5288.

ORDERING REPLACEMENT PARTS

To order additional parts and attachments, please visit ninjaccessories.com or contact Customer Service at 1-877-646-5288.

⚠ WARNING: To reduce the risk of shock and unintended operation, turn power off and unplug unit before troubleshooting.

Unit doesn't turn on.

- Make sure unit is plugged in.
- Display will read "--" once connected to power.
- Place container on base and rotate it clockwise until it clicks into place. Press the Power symbol to turn unit on, and the available programs will illuminate indicating the unit is ready for use. Available programs will illuminate indicating the unit is ready for use.

Unit doesn't turn off.

- Remove container from base by rotating it counterclockwise and lifting it. Display should turn off. Unplug the power cord from the outlet.

Lid/Pro Extractor Blades Assembly is hard to install on the cup.

- Set the cup on a level surface. Carefully place the lid or Pro Extractor Blades Assembly on the top of the cup and align the threads so the lid/Pro Extractor Blades Assembly sits flat on the cup. Twist clockwise until you have a tight seal.

Food is not evenly chopped.

- For best results when chopping, cut pieces down to even sizes and do not overfill the Precision Processor™ bowl.

Doesn't mix well; ingredients get stuck.

- Using the pre-set programs is the easiest way to achieve great results. The pulses and pauses allow the ingredients to settle toward the blade assembly. If ingredients are routinely getting stuck, adding some liquid will usually help.
- When filling the cup, start with fresh fruit or veggies, then leafy greens or herbs. Next add liquids or yogurt, then seeds, powders, or nut butters. Finally, add ice or frozen ingredients.

Motor base won't stick to counter or tabletop.

- Make sure surface and suction feet are wiped clean. Suction feet will only stick to smooth surfaces.
- Suction feet **WILL NOT** stick on some surfaces such as wood, tile, and non-polished finishes.
- **DO NOT** attempt to use unit when the motor base is stuck to a surface that is not secure (cutting board, platter, plates, etc.).

Unit is difficult to remove from counter for storage.

- Place your hands underneath both sides of the motor base and gently pull the unit up and toward you.

You get a blinking "--" Message

- Smart Vessel Recognition can detect which container is on the motor base. You may be trying to use a program that is not designed for the container you have installed. The programs will light up, indicating which programs are available for each container.

You cannot create snow from solid ice.

- Do not use ice that has been sitting out or has started to melt. Use ice straight from the freezer.
- Start with a few pulses and then go to a continuous blending cycle.

You get semi-circular or shredded noodles.

- If the Collecting Bowl is overfilled, causing the Blade Disc to lift up after spiralizing, your ingredient may have been too large. Make sure to trim and prepare your ingredients properly before spiralizing by following the instructions in the Food Prep section in your Quick Start Guide or Inspiration Guide.
- For the most consistent results, be sure to center the ingredient onto the pin located in the center of the Blade Disc. (Refer to page 27, step 2).

Ingredient is not fully processed and is spinning below the pusher.

- Remove remaining ingredient from Blade Disc pin and trim top and bottom so that both are flat. Make sure you center ingredient on the Blade Disc pin and secure the food pusher firmly on top of the ingredient. While maintaining pressure on food pusher, press the GO button to begin spiralizing.

SOY BEAN DIP RECIPE



CONTAINER

710ml Slim High Speed Blender Cup

INGREDIENTS

280g dried soy beans

DIRECTIONS

- 1** Clean and dry jar and blade
- 2** Place soy beans into the Slim High Speed Blender Cup.
- 3** Select HIGH for 60 seconds

Mann&Noble

Mann&Noble Pty Ltd
No 1 Southridge Unit Estate
2 Southridge Street
Eastern Creek NSW
Australia, 2766

TEL. 1800 099 385

www.ninjakitchen.com.au

Illustrations may differ from actual product. We are constantly striving to improve our products, therefore the specifications contained herein are subject to change without notice.

NINJA is a registered trademark of SharkNinja Operating LLC.

For SharkNinja U.S. Patent information, visit sharkninja.com/uspatents

© 2018 SharkNinja Operating LLC
CT682ANZ_IB_REV_Mv2

PRINTED IN CHINA / IMPRIMÉ EN CHINE / IMPRESO EN CHINA



[@ninjakitchen](https://www.instagram.com/ninjakitchen)