

# NINJA®

## FOODI™ BLENDER

# HB150ANZ Series

## OWNER'S GUIDE



[AU ninjakitchen.com.au](http://AU.ninjakitchen.com.au)

[NZ ninjakitchen.co.nz](http://NZ.ninjakitchen.co.nz)

# THANK YOU

for purchasing the Ninja® Foodi™ Blender

## REGISTER YOUR PURCHASE

 **AU** ninjakitchen.com.au  
**NZ** ninjakitchen.co.nz

## RECORD THIS INFORMATION

Model Number: \_\_\_\_\_  
Serial Number: \_\_\_\_\_  
Date of Purchase: \_\_\_\_\_  
(Keep receipt)  
Store of Purchase: \_\_\_\_\_

## TECHNICAL SPECIFICATIONS

Voltage: 220-240V~, 50-60Hz  
Watts: 1000W

## PLEASE READ CAREFULLY AND KEEP FOR FUTURE REFERENCE.

These instructions are designed to help you get a complete understanding of your new Ninja Foodi Blender.

If you have any questions, please call our Customer Service line at **AU** 02 8801 7666 or **NZ** 0800 112 660

**TIP:** You can find the model and serial numbers on the label on the back of the motor base.

# CONTENTS

<b>Important Safety Instructions</b> .....	<b>4</b>
<b>Parts</b> .....	<b>6</b>
<b>Features</b> .....	<b>7</b>
Auto-iQ® Programs .....	7
Manual Settings .....	7
<b>Before First Use</b> .....	<b>8</b>
<b>Handling the Blender Pitcher</b> .....	<b>9</b>
<b>Getting Started With Your Blender</b> .....	<b>10</b>
Assembling the Heated Blender .....	10
Auto-iQ® Programs .....	11
Manual Blend .....	11
Manual Cook .....	11
<b>Care &amp; Maintenance</b> .....	<b>12</b>
Cleaning .....	12
Storing .....	12
Resetting the Motor Thermostat .....	12
Ordering Replacement Parts .....	12
<b>Display Screen &amp; Error Messages</b> .....	<b>13</b>
<b>Troubleshooting Guide</b> .....	<b>14</b>
<b>Warranty</b> .....	<b>15</b>

# IMPORTANT SAFETY INSTRUCTIONS

PLEASE READ CAREFULLY BEFORE USE • FOR HOUSEHOLD USE ONLY

## ⚠ WARNING

**To reduce the risk of injury, fire, electrical shock or property damage, basic safety precautions must always be followed, including the following numbered warnings and subsequent instructions.**

**Extreme caution must be used when moving an appliance containing hot oil or other hot liquids.**

**Do not use appliance for other than intended use.**

- 1 Read all instructions prior to using the appliance and its accessories.
- 2 Carefully observe and practice all warnings and instructions. This unit contains electrical connections, moving parts, and heating elements that potentially present risk to the user.
- 3 Take your time and exercise care during unpacking and appliance setup.
- 4 Take inventory of all contents to ensure you have all parts needed to properly and safely operate your appliance.
- 5 Blades are sharp. Handle carefully.
- 6 Turn the appliance OFF, then unplug the appliance from the outlet when not in use, before assembling or disassembling parts, and before cleaning. To unplug, grasp the plug by the body and pull from the outlet. **NEVER** unplug by grasping and pulling the flexible cord.
- 7 Wash all parts that may contact food before use. Follow washing instructions covered in this instruction manual.
- 8 To protect against the risk of electric shock, **DO NOT** submerge the appliance or allow the power cord to contact any form of liquid.
- 9 **DO NOT** use this appliance outdoors. It is designed for indoor household use only.
- 10 **DO NOT** operate any appliance with a damaged cord or plug, or after the appliance malfunctions or is dropped or damaged in any manner. This appliance has no user-serviceable parts. If damaged, contact SharkNinja for servicing.
- 11 This appliance has important markings on the plug blade. The entire supply cord is not suitable for replacement. If damaged, please contact SharkNinja for service.
- 12 Extension cords should not be used with this appliance.
- 13 **DO NOT** allow children to operate this appliance or use as a toy. Close supervision is necessary when any appliance is used near children.
- 14 This appliance is not intended to be used by people with reduced physical, sensory, or mental capabilities, or lack of experience and knowledge, unless they have been given supervision or instruction concerning use of the appliance by a person responsible for their safety.
- 15 **Cleaning and user maintenance shall not be carried out by children.**
- 16 **Keep the appliance and its cord out of reach of children.**
- 17 Before each use, inspect blade assemblies for damage. If a blade is bent or damage is suspected, contact SharkNinja to arrange for replacement.
- 18 **DO NOT** attempt to sharpen blades.
- 19 **DO NOT** let cord hang over edge of table or counter or touch hot surfaces.
- 20 **DO NOT** allow the unit or the cord to contact hot surfaces, including stoves and other heating appliances.
- 21 **DO NOT** place on or near a hot gas or electric burner or in a heated oven.

- 22 **ALWAYS** use the appliance on a dry and level surface.
- 23 Keep hands, hair, and clothing out of the container when loading and operating.
- 24 **ONLY** use attachments and accessories that are provided with the product or are recommended by SharkNinja. The use of attachments, including canning jars, not recommended or sold by SharkNinja may cause fire, electric shock, or injury.
- 25 During operation and handling of the appliance, avoid contact with moving parts.
- 26 **DO NOT** operate the appliance with an empty container.
- 27 **DO NOT** fill containers past the max fill or max liquid lines.
- 28 **DO NOT** microwave any containers or accessories provided with the appliance.
- 29 Before operation, ensure all utensils are removed from containers. Failure to remove utensils can cause containers to shatter and potentially result in personal injury and property damage.
- 30 Keep hands and utensils out of container while blending to reduce the risk of severe injury to persons or damage to the blender. A rubber scraper or spatula may be used but must be used **ONLY** when the blender is not running.
- 31 **NEVER** operate the appliance without lids and caps in place. **DO NOT** attempt to defeat the interlock mechanism. Ensure the container and lid are properly installed before operation.
- 32 **DO NOT** expose the containers and accessories to extreme temperature changes. They may experience damage.
- 33 **Be careful if hot liquid is poured into the food processor or blender as it can be ejected out of the appliance due to a sudden steaming.**
- 34 **NEVER** leave the appliance unattended while in use.
- 35 **ALWAYS** operate blender with cover in place.
- 36 Allow to cool before assembling or disassembling parts and before cleaning appliance.
- 37 **DO NOT** grasp the sides of the pitcher after hot blending or cooking. The surface of the pitcher is hot during and after operation. Surfaces are hot during and after operation. To prevent burns or personal injury, **ALWAYS** use protective hot pads or insulated oven mitts and use available handles and knobs.
- 38 If you find unmixed ingredients sticking to the sides of the pitcher, stop the appliance, remove the lid, and use a rubber scraper or spatula to dislodge ingredients. **NEVER** insert your hands into the pitcher, as you may contact one of the blades and experience a laceration.
- 39 **DO NOT** attempt to remove the container and lid from the motor base while the motor is still spinning. Allow the appliance to come to a complete stop before removing the lid and pitcher.
- 40 If the appliance overheats, a thermal switch will activate and temporarily disable the motor. To reset, unplug the appliance and allow it to cool for approximately 5 minutes before using again.
- 41 The maximum wattage rating for this appliance is based on the configuration of the high-speed bottom blade and glass pitcher blender. Other configurations may draw less power or current.
- 42 **Turn off the appliance and unplug the motor base before cleaning.**

## SAVE THESE INSTRUCTIONS

## PARTS

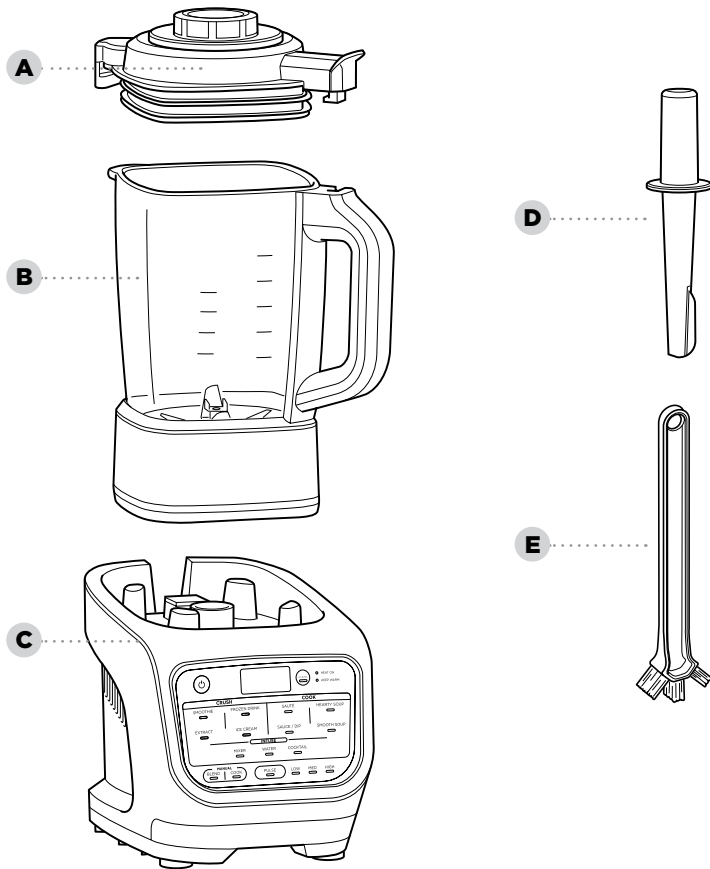

- A** Pitcher Lid with Removable Centre Cap
- B** 1.8L.\* Glass Pitcher with Built-in Heating Element  
\*1.6L max cold liquid and 1.4L max hot liquid capacity
- C** Motor Base  
(attached power cord not shown)
- D** Tamper
- E** Cleaning Brush

## FEATURES

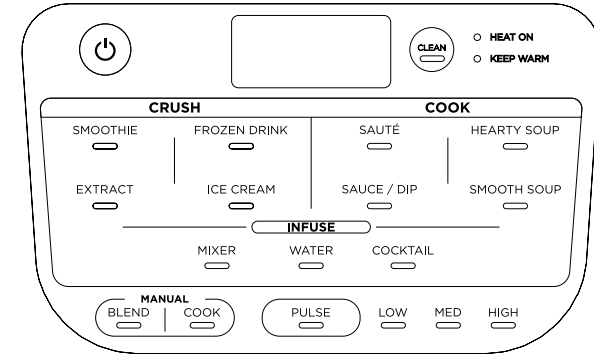

### AUTO-IQ® PROGRAMS:

Intelligent programs that combine unique pulsing, blending, pausing, and heating patterns that do the work for you.

#### Smoothie (0:45)

Combine your favourite fresh or frozen ingredients, liquids, and powders to create smoothies and protein shakes.

#### Extract (1:05)

Ideal for tough, leafy, or fibrous whole fruits and vegetables, including their skins, seeds, and stems.

#### Frozen Drink (0:55)

Crush ice and frozen fruit into restaurant-style frozen drinks.

#### Ice Cream (1:10)

Use your favourite frozen fruit and dairy to make sorbets and frozen treats.

#### Sauté (5:21)

Unlock more flavor by quickly cooking onions, garlic, spices, and more before creating homemade soups, sauces and dips.

#### Sauce/Dip (30:30)

Create sweet or savoury sauces and fondue.

#### Hearty Soup (30:00)

Create homemade soup with more texture.

#### Smooth Soup (30:00)

Cook and blend your favourite silky-smooth soups.

#### Mixer (10:30)

Use sweet or savoury ingredients to create bold-flavored concentrates.

#### Water (10:30)

Create fruit water or wellness tonics and teas.

#### Cocktail (10:30)

Quickly infuse liquor or create craft cocktails.

### MANUAL SETTINGS:

#### Blend

Select BLEND, then choose either LOW, MED or HIGH blending speed. The setting will run for 60 seconds or until manually stopped.

#### Cook

Select COOK, then choose either LOW, MED or HIGH temperature. The setting will run for 60 minutes or until manually stopped.

#### Pulse

Select either BLEND or COOK, then press PULSE to process ingredients to your desired texture and consistency.

### OTHER FEATURES:

#### Power Button

Use to turn the unit on or off.

#### Clean (6:36)

Combines heat and rapid pulses to remove stuck-on messes.

#### Heat On

Light will turn on when you have selected a program or function that uses heat.

#### Keep Warm

Light will turn on after cooking, and the unit will keep contents warm for up to 60 minutes.

## BEFORE FIRST USE

**IMPORTANT:** Review all warnings on pages 4–5 before proceeding.

- 1 Remove all packaging material and labels from the appliance. Separate all parts from each other.
- 2 Wash the pitcher, lid, and accessories with warm, soapy water. Use a dishwashing utensil with a handle to avoid contact with the blades.

**NOTE:** Follow cleaning instructions on page 12 very carefully.

- 3 Thoroughly rinse and air-dry all parts.

**NOTE: DO NOT** submerge the pitcher when washing.

## HANDLING THE BLENDER PITCHER

### LIFTING AND POURING FROM THE PITCHER

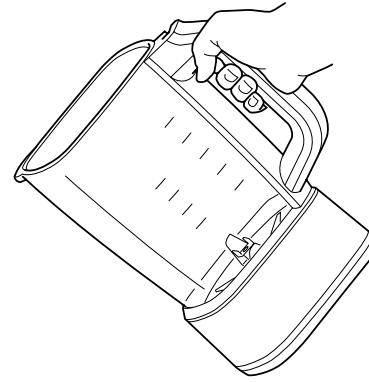

Firmly grasp the handle with one hand and carefully pour out ingredients.

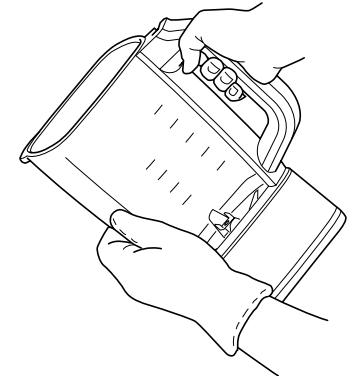

**NOTE:** If pitcher feels too heavy in one hand, use a protective mitt or glove and support the pitcher weight with your other hand.

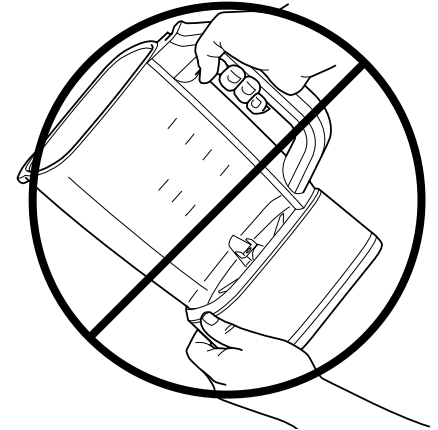
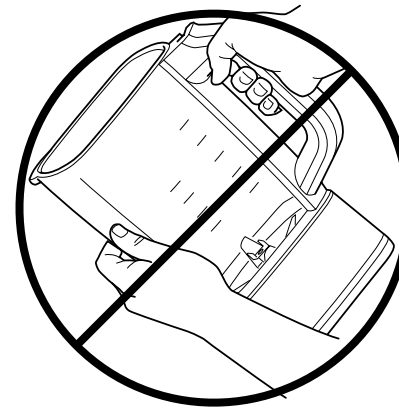

**DO NOT** grasp pitcher after hot blending or cooking. Surfaces are hot during and after operation. To prevent burns or personal injury, **ALWAYS** use protective hot pads or insulated oven mitts and use available handles and knobs.

# GETTING STARTED WITH YOUR BLENDER

**IMPORTANT:** Review all warnings on pages 4–5 before proceeding.

## ASSEMBLING THE HEATED BLENDER

- 1 Plug in motor base and place on a clean, dry, level surface such as a countertop or table.
- 2 Lower the pitcher onto the motor base.

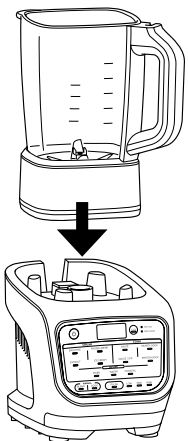

- 3 Add ingredients, making sure to not exceed the max fill lines on side of pitcher. In COOK or INFUSE modes, DO NOT exceed the level labelled “SOUP.” In BLEND mode, DO NOT exceed the level labelled “COLD.”

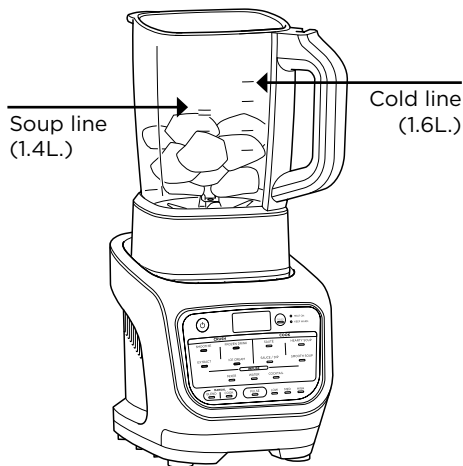

- 4 To install the lid on the pitcher, place the lid tab to the right of the handle. Press the lid down until it is secure. Rotate the tab clockwise so the arrow on the lid tab aligns with the arrow on the pitcher handle.

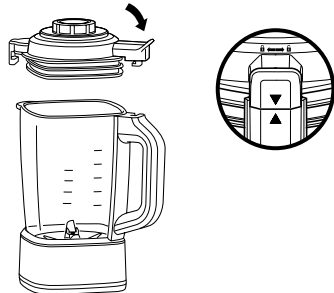

- 5 Secure the centre cap by placing it down into the lid and twisting clockwise until it clicks into place.

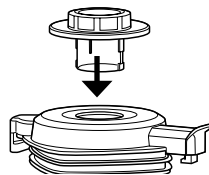

- 6 To remove the lid from the pitcher, rotate lid counterclockwise out of the lock position and lift up.

**NOTE:** After heated programs, steam may release as the lid is removed. Keep hands on the outer tabs and lift directly up.

## AUTO-IQ® PROGRAMS

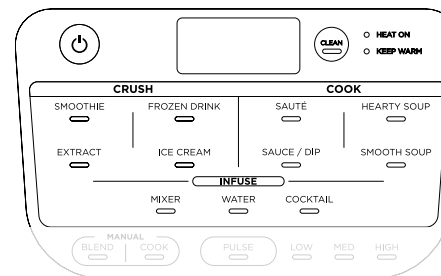

- 1 To begin, press the Power button.
- 2 Press the program of your choice from the CRUSH, COOK or INFUSE sections.
- 3 The Heat On light will turn on if the selected program uses heat.

**TIP:** When making thicker recipes such as ice creams and dips, use the tamper to push ingredients toward the blades. Tamper should be used only when lid is attached to pitcher. Remove centre cap and replace with tamper.

**NOTE:** The unit will beep 3 times to alert you the program is going to stir ingredients. Make sure centre cap is secure during use.

## MANUAL SETTINGS

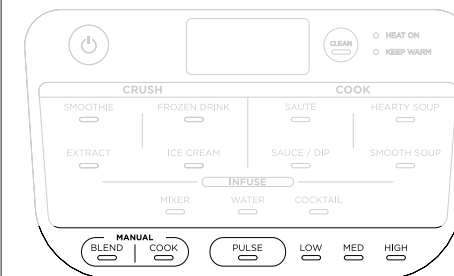

### MANUAL BLEND

Manual Blend speeds give you ultimate control over your blend.

- 1 To begin, press the Power button.
- 2 Choose BLEND to unlock speed options.
- 3 Select LOW, MED, HIGH or PULSE to begin blending.

**NOTE:** The Pulse setting will run only when the PULSE button is pressed.

### MANUAL COOK

Manual Cook settings puts the control in your hands.

- 1 To begin, press the Power button.
- 2 Choose COOK to unlock temperature options.
- 3 Select LOW, MED or HIGH to begin cooking.
- 4 Timer will count up to 60 seconds or until manually stopped.

**NOTE:** You can press PULSE during Manual Cook mode to gently stir ingredients.

**NOTE:** For best results, quickly PULSE ingredients periodically during cooking to distribute heat and promote even cooking.

## CARE & MAINTENANCE

**IMPORTANT:** Review all warnings on pages 4–5 before proceeding.

### CLEANING

Allow parts to cool before cleaning. Separate all parts before cleaning.

#### Hand-Washing

Wash the pitcher, lid and tamper with warm, soapy water. Use the included cleaning brush to avoid direct contact with the blades.

**NOTE: DO NOT** submerge the blender pitcher. Submerging will damage the integrated heating element.

#### Dishwasher

The lid, centre cap, and tamper are dishwasher safe.

**NOTE: DO NOT** wash the blender pitcher in the dishwasher. Dishwashing will damage the integrated heating element.

#### Motor Base

Press the power button to turn off the unit, then unplug the motor base. Wipe motor base with a clean, damp cloth.

### CLEAN

A combination of heat and rapid pulses easily removes residue from the nonstick coating in minutes.

- 1 Fill pitcher with 700ml of water and 2 small drops of dish soap.
- 2 Place the lid on the pitcher and ensure it is properly closed.
- 3 Press CLEAN.
- 4 When program is complete, discard water and thoroughly rinse pitcher.

#### TIPS FOR BEST CLEANING RESULTS:

- Give the pitcher a quick rinse before running CLEAN.
- Run CLEAN immediately after use.

### STORING

Store the unit upright with the lid secured on the pitcher.

**NOTE: DO NOT** stack items on top of the unit. Store any remaining attachments alongside the unit or in a cabinet where they will not be damaged or create a hazard.

### RESETTING THE MOTOR

This unit features a unique safety system that prevents damage to the motor by temporarily disabling the motor if it begins to overheat. Should this occur, follow the reset procedure below.

- 1 Unplug the unit from the electrical outlet.
- 2 Allow the unit to cool for approximately 15 minutes before using.

**IMPORTANT:** Ensure that maximum capacities are not exceeded. This is the most typical cause of appliance overload.

### ORDERING REPLACEMENT PARTS

To order additional parts and attachments, visit [ninjakitchen.com.au](http://ninjakitchen.com.au) or [ninjakitchen.co.nz](http://ninjakitchen.co.nz)

## DISPLAY SCREEN & ERROR MESSAGES

### DISPLAY SCREEN MESSAGES

#### “Lid”

The lid is not assembled correctly. Be sure the lid is on the pitcher and locked in place before running a program.

#### “Jar”

The pitcher is not properly attached to the base. Be sure the pitcher is secured in the base before selecting a program.

#### “---” Blinking

You are attempting to run a program too many times in a row. For your safety, certain programs may be run only two consecutive times.

**NOTE: DO NOT** attempt to remove the pitcher while the blender is running. Wait for the blades to stop spinning before removing the pitcher.

### ERROR MESSAGES

#### “E01” or “E02”

Remove and reinstall the pitcher. If that does not solve the issue, contact Customer Service at AUS 02 8801 7666 or NZ 0800 112 660. So we may better assist you, please register your product online at [ninjakitchen.com.au](http://ninjakitchen.com.au) or [ninjakitchen.co.nz](http://ninjakitchen.co.nz) and have the product on hand when you call.

## TROUBLESHOOTING GUIDE

**⚠ WARNING: To reduce the risk of shock and unintended operation, turn power off and unplug unit before troubleshooting.**

### **Unit doesn't turn on.**

- Make sure unit is plugged in.
- Display will light up with usable programs once connected to power. Pitcher and lid must be engaged to select a program.

### **Lid is stuck on pitcher.**

- The lid is removed by rotating from the handle counterclockwise and then lifting up.

### **Cannot change time or temperature settings on Auto-iQ® programs.**

- All programs were developed by culinary experts to deliver the perfect balance of heating, stirring, and blending patterns to give perfect results, so you do not have to set the time or temperature.
- To select a specific temperature, use the Manual COOK setting instead of an Auto-iQ program.

### **Program has paused.**

- If the lid was removed while running a program or while in a Manual mode, the cooking or blending function will pause. Replace the lid and push the program button again to continue from where the time left off.

### **Why does the blender sometimes count up and other times count down?**

- Auto-iQ programs are timed to finish on their own when they are complete, so the clock counts down until the program has finished. When using Manual modes, the clock will count up from 0 until the auto shutoff time is reached or the button for the currently running mode is selected again.

### **My pitcher will not assemble to the base**

- Make sure the Ninja® logo is facing forward before placing the pitcher directly onto the blender base. If the pitcher is still not fully seated, rotate the coupling under the pitcher to help align it to the base.

### **Pitcher still has residue after running the Clean program.**

- Try running the CLEAN program a second time. You may also hand-wash the pitcher using the included cleaning brush, which is specifically designed to clean those hard-to-reach areas.

### **The control panel returns to home display.**

- The control panel is designed to return to standby mode when left inactive for 3 minutes. If you have taken longer than 3 minutes to choose a function, or if the program has finished, the unit will return to standby mode.

### **Why does the unit beep during Auto-iQ Programs?**

- We've incorporated STIR ALERT within all Auto-iQ programs to let you know the unit is about to stir. The alert is 3 beeps followed by a 2-second pause before each stir.

# Shark | NINJA

## ONE (1) YEAR LIMITED WARRANTY

For warranty claims, you will need to submit a proof of purchase in the form of a valid receipt that displays date and place of purchase. This warranty does not replace but is in addition to your statutory rights.

If your product becomes defective due to faulty material or workmanship within a period of 1 year from the date of purchase, we warrant to do the following:

- For New Zealand Consumers: We will replace the defective/faulty part with a new product, free of charge, or if the unit is deemed defective/faulty we replace the unit with an equivalent or upgraded model, at our discretion.
- For Australian Consumers: Our goods come with guarantees that cannot be excluded under the Australian Consumer Law. You are entitled to a replacement or refund for a major failure and for compensation for any other reasonably foreseeable loss or damage. You are also entitled to have the goods repaired or replaced if the goods fail to be of acceptable quality and the failure does not amount to a major failure.

Replacement items will be covered by the limited warranty for the balance of the warranty period from the date of the original purchase. Please note:

### **Your warranty is subject to the following conditions**

- DO NOT operate the appliance with a damaged plug or cord, or if the unit has been dropped, damaged or dropped in water.
- To avoid the risk of electric shock, do not disassemble or attempt to repair the appliance on your own. If the supply cord is damaged, it must be replaced by a qualified electrician to avoid a hazard. Incorrect re-assembly or repair can cause a risk of electric shock or injury to persons when the appliance is used.
- The item has not been misused, abused, neglected, altered, modified or repaired by anyone.
- The item has been subjected to fair wear and tear.
- The item has not been used for trade, professional or hire purposes.
- The item has not sustained damage through foreign objects, substances or accident

### **What is not covered?**

- Accessories supplied with the item.
- Components that are subject to natural wear and tear caused by normal use in accordance with operating instructions.
- Unauthorised/improper maintenance/handling or overload is excluded from this warranty.



VISIT US ONLINE AT:

**AU** [ninjakitchen.com.au](http://ninjakitchen.com.au) **NZ** [ninjakitchen.co.nz](http://ninjakitchen.co.nz)

Or follow us on any of our social media pages:

**f**  @ninjakitchenanz

**Mann&Noble**

**No 1 Southridge Unit Estate**

**2 Southridge Street**

**Eastern Creek**

**NSW 2766, Australia**

**AU 02 8801 7666 | NZ 0800 112 660**

**AU [ninjakitchen.com.au](http://ninjakitchen.com.au) | NZ [ninjakitchen.co.nz](http://ninjakitchen.co.nz)**

Illustrations may differ from actual product. We are constantly striving to improve our products, therefore the specifications contained herein are subject to change without notice.

AUTO-IQ and NINJA are registered trademarks of SharkNinja Operating LLC.

FOODI is a trademark of SharkNinja Operating LLC.

© 2019 SharkNinja Operating LLC

PRINTED IN CHINA

HB150ANZ\_Series\_IB\_MP\_Mv4

